

Crystal or oscillator – which one and how to apply?

When designing a new electronic circuit, design engineers often need to consider if a crystal or an oscillator is the suitable choice: How much space is available? Which are the requirements for frequency stability? What about the costs for the components and for developing this part of the circuit?

Small quantities – an oscillator is the appropriate choice

By using a crystal, design engineers can build any oscillating circuit. So why are readily available oscillators often used even in simple applications like for clock generation? Obviously the reason is not only the required frequency stability. Secured start-up conditions as well as reliability for any required environmental condition will also play a role. Furthermore, the use of crystals needs certain efforts to adapt the circuit to the crystal and to secure a reliable start-up performance of the circuit.

Thus it will be recommendable for small quantities to save design costs and to use a more expensive oscillator rather than a crystal. By using an oscillator, no further external components as for a crystal are required. This also might save space on the PCB. Oscillators are easily available, for example with a size of 7 x 5mm SMD or even smaller (pic. 1). Manuals of microcontrollers usually contain information how to apply an external oscillator.

Building an own oscillating circuit by crystals and discrete components may get economical for larger quantities or if an IC with internal oscillator is not being used. Pierce or Colpitts oscillator may be chosen. Furthermore it is possible to create an oscillator by an appropriate feedback of an inverter circuit (pic. 2).

Application of crystals to microcontrollers

Most microcontrollers already contain the elementary components for the clock circuit. In order to complete the circuitry to a Pierce or a Colpitts oscillator type, just a crystal and other external passive components are required. Application manuals of the microcontroller describe the necessary details. In order to minimize any parasitic effects, all connections from microcontroller to the crystal circuitry should be kept as short as possible.

At frequencies of 40MHz and above, overtone crystals are being used. These overtone crystals require a special filter circuit in order to suppress the fundamental mode. The filter circuit consists of capacitor and inductance. If the filter is omitted, the circuit oscillates at its fundamental mode (example: 3rd overtone crystal at 48MHz being expected, circuit oscillates at 16MHz). Oscillator circuits with overtone crystals should be very dimensioned and tested with the utmost care.

Pierce oscillator with external crystal (in fundamental mode)

If a microcontroller is equipped with a Pierce oscillator configuration, the crystal will be connected to two capacitors like in pic. 3 (C_1 and C_2). For frequencies above 4MHz no additional series resistor is required, since an appropriate series resistor will usually be included within the inverter stage of the microcontroller. Moreover the high-ohmic resistor is integrated within the microcontroller in order to adjust the DC operating voltage (1 MΩ in pic. 3). C_{S1} and C_{S2} include input and output capacitance of the microcontroller as well as other capacitances contributed by conducting paths on the PCB. The overall circuit capacitance is adapted to the specified load capacitance of the crystal C_L by the external capacitors C_1 and C_2 :

$$\frac{(C_1 + C_{S1}) \times (C_2 + C_{S2})}{(C_1 + C_{S1} + C_2 + C_{S2})} = C_L \quad \text{(equation 1)}$$

Example: $C_L = 16\text{pF}$ provided. Assumed $C_{S1} = C_{S2} = 12\text{pF}$ the external capacitors can be evaluated to $C_1 = 15\text{pF}$ and $C_2 = 27\text{pF}$. These should be considered as initial values for a following optimization. C_1 is smaller than C_2 in order to enhance the start-up performance of the circuit.

The crystal circuit is in its optimum if the frequency matches the actual resonance frequency of the crystal. The actual resonance frequency of the crystal at its specified load capacitance can be found in its test record.

The frequency shall be measured without any feedback from the probe. Often this can be achieved by measuring the frequency at another port of the microcontroller. If the crystal is overloaded by the capacitors, the frequency is smaller than required (otherwise it is larger).

Series resistor for Pierce oscillator

As mentioned above, an external series resistor may be needed for microcontrollers with Pierce oscillator configuration for frequencies below 4MHz. The series resistor R_V will help to suppress unwanted overtones as well as to adapt the internal oscillator to the external pi-circuit, which consists of C_1 , C_2 and the crystal. Series resistor R_V can be evaluated as follows: R_V is in series with capacitor C_2 and thus functions as low-pass filter (pic. 2). The value of C_2 already shall be provided. By choosing R_V the cut-off frequency f_T shall be between fundamental mode frequency and 3rd overtone (equations 2 and 3).

$$f_T = 2 \cdot f_0 \quad (\text{equation 2})$$

$$R_V = 1 / (2 \pi f_T C_2) \quad (\text{equation 3})$$

Example: Crystal resonant frequency 2MHz and $C_2 = 22\text{pF}$ provided. Hence, $f_T = 2 \times 2\text{MHz} = 4\text{MHz}$ and $R_V = 1.8 \text{ k}\Omega$.

Colpitts oscillator with external crystal (in fundamental mode)

If the microcontroller provides a Colpitts oscillator configuration, the microcontroller shows a circuit like in pic.

4. The capacitors C_1 and C_2 are chosen as described by equation (1).

Example: $C_L = 16\text{pF}$ provided. Assumed $C_{S1} = C_{S2} = 10\text{pF}$, the external capacitors can be evaluated to $C_1 = C_2 = 22\text{pF}$.

As already mentioned above, frequency shall be measured without feedback from any probe.

Microcontroller with only one input for fundamental mode crystal

Sometimes the manual of the microcontroller shows only one input for the crystal. The crystal as well as a capacitor are connected to ground as can be seen in pic. 5. Either the intention of the microcontroller manufacturer is to adjust the load capacitance or to ensure DC insulation for the crystal (or both).

A practicable solution is to choose a capacitance value, which is approximately the same as the specified load capacitance of the crystal (equation 4).

$$C_1 \approx C_L \quad (\text{equation 4})$$

Example: $C_L = 16\text{pF}$ provided. A suitable initial value for an optimization is $C_1 = 16\text{pF}$. This value should be checked and corrected by feedback-free frequency measurements, respectively.

Margin for start-up should always be checked

In order to check if the crystal can reliably start to oscillate, a resistor can be soldered manually in series to the crystal. SMD resistors are most suitable for this test. The circuit shall oscillate even if the resistor value is by a factor of X higher than the maximum specified resonant resistance of the crystal.

The maximum specified resonant resistance of the crystal can be found in its data sheet. The factor X should be 3 to 5 within the whole required temperature range. For special applications an even higher factor X is appropriate.

Example: Resonant resistance R_r , max = 100Ω provided. If the circuit is used for industrial purposes, the circuit shall work properly even if the manually soldered test resistor has a value of 300Ω to 500Ω .

Conclusion

For smaller quantities it is more economical to apply oscillators rather than crystals. Oscillators are easy to apply and provide reliable operation. For larger quantities and when used as simple clock generator only, crystals are more reasonable than oscillators. This article describes how the required external components can be evaluated. Furthermore, a simple method for checking the startup performance is presented.



Pic. 1: SMD Crystal Oscillator with a size of 7 x 5mm. Such oscillators are available for a frequency range of 1MHz to 160MHz and for supply voltages of 1,8 V / 2,5 V / 3,0 V / 3,3 V and 5 V. (GEYER Electronic)

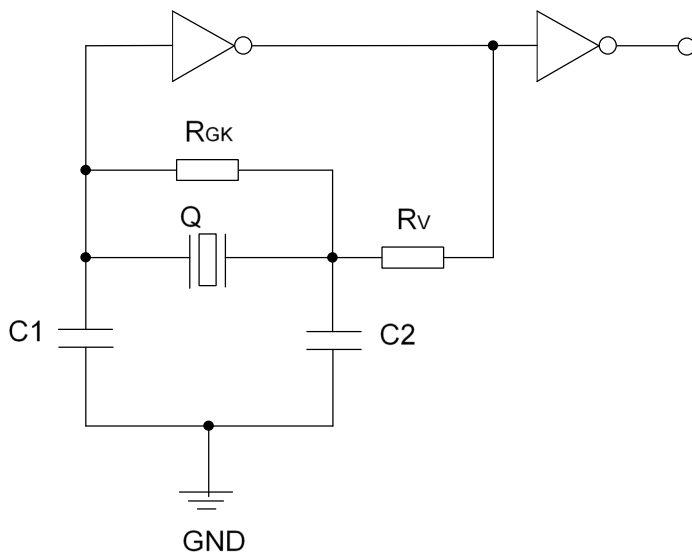

Pic. 2: Pierce oscillator circuit with regenerative inverter and a fundamental mode crystal. RGK is a high-ohmic resistor for adjustment of the DC-operating voltage.

RV is a series resistor for suppressing overtone frequencies. C₁ and C₂ are used to adjust the overall capacitance load to the specified load capacitance of the crystal. RV, crystal, C₁ and C₂ provide a phase shift. Together with the 180° phase shift of the (amplifying) inverter, the necessary condition for oscillation can be achieved.

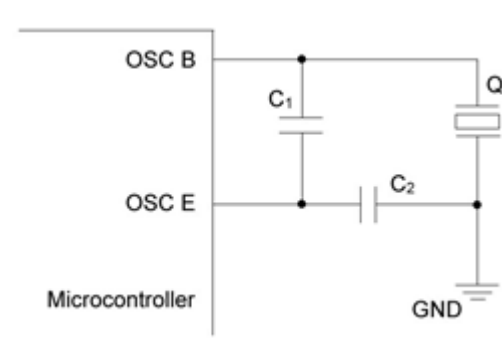

Pic. 3: Typical external circuit of a microcontroller with Pierce oscillator configuration.

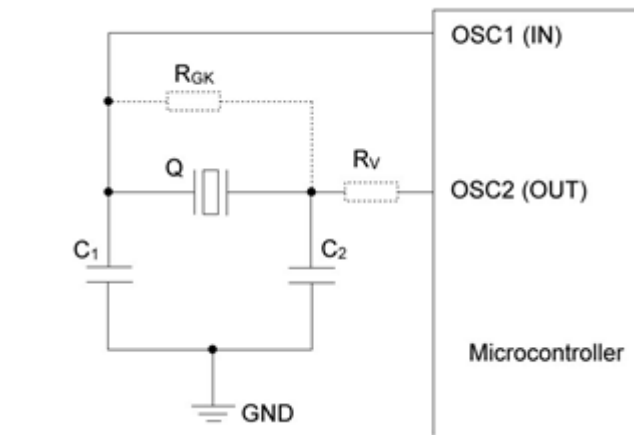

Pic. 4: Typical external circuit of a microcontroller with Colpitt oscillator configuration.

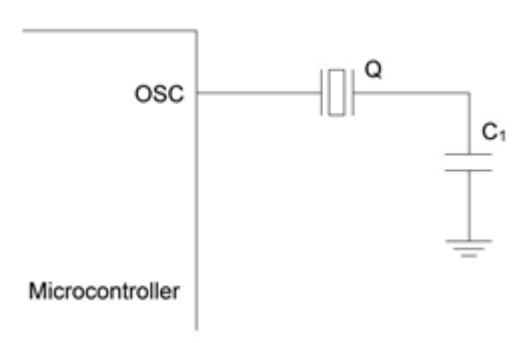

Pic. 5: Example if a microcontroller manual shows just one input for a crystal.