



## Quartz Crystal

SMD-version

model	KX - KS
frequency	11,05920 MHz
mode	fundamental
operating temperature	-20° ~ +70°C
frequency tolerance at +25°C	± 50 ppm
temperature tolerance at -20° ~ +70°C	± 50 ppm
load capacitance $C_L$	16 pF
series resonance R1 max.	80 Ohm
aging at 25°C (first year) max.	± 2 ppm
shunt capacitance $C_0$ max.	7,0 pF
drive level	0,1 mW
contents of reel	1000 pcs.
part no.	12.88010

### Dimensions (mm):

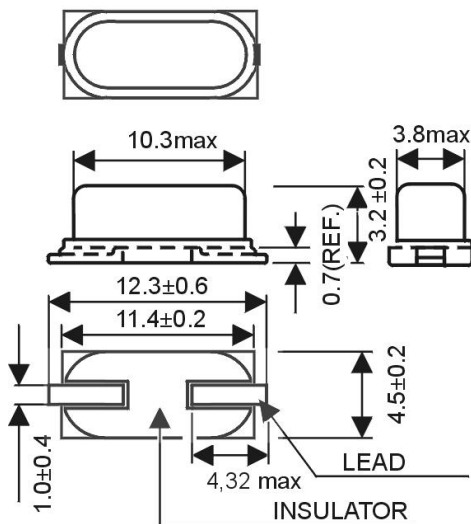

### Suggested soldering pad:

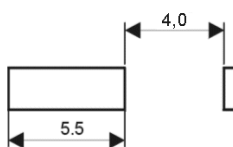

### Reflow soldering condition:

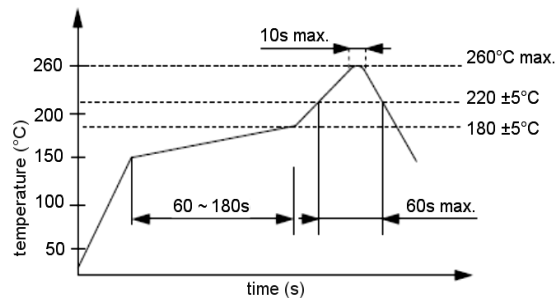

### Tape specification:

