

Possible tabs for Lithium cells

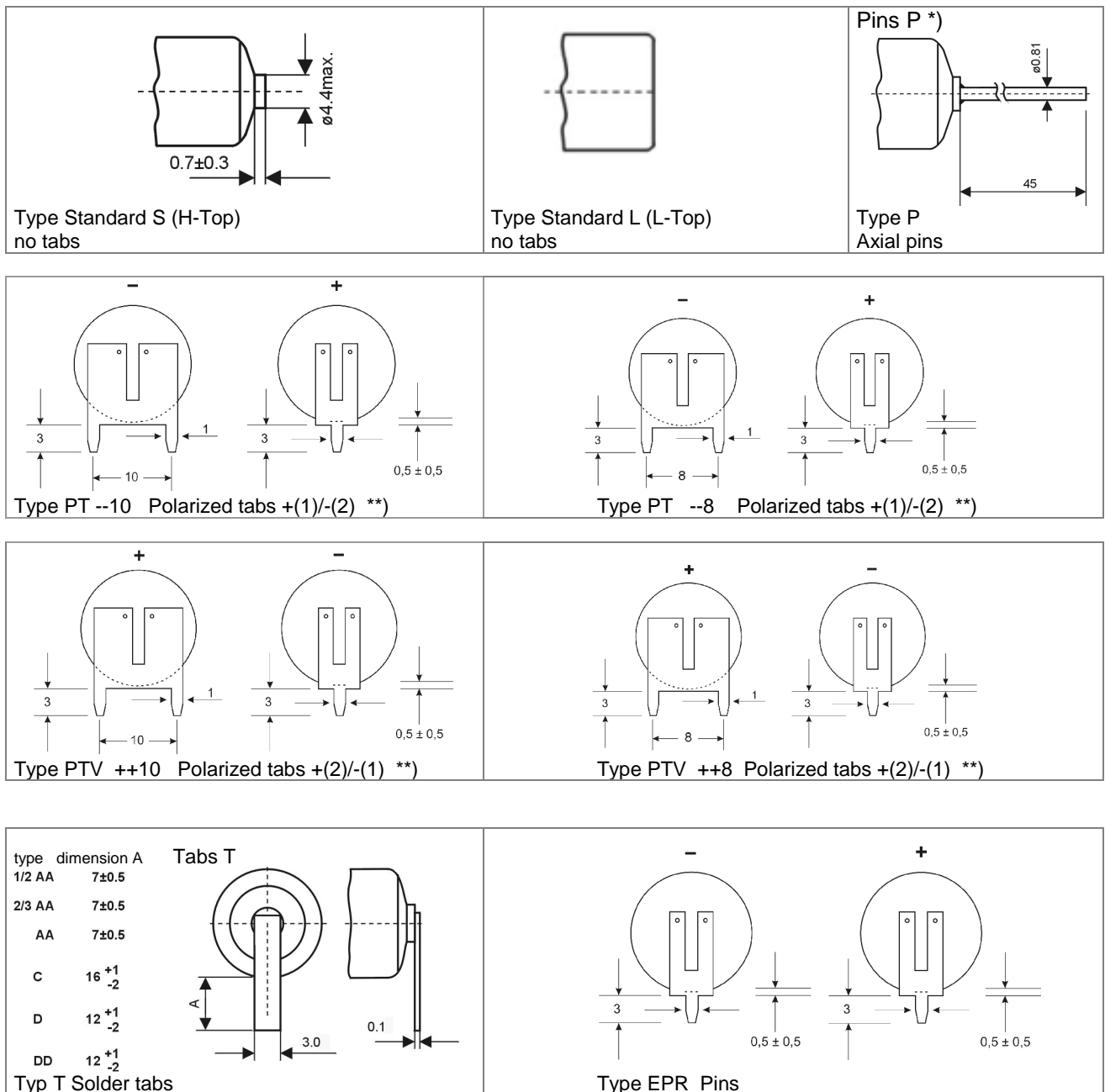

*) Please notice our Customer Information according to the processing of cells w/ axial pins (/P versions) next page.

**) available for sizes 1/2 AA, and AA only

*) Customer Information
according processing of cells w/ axial pins (/P versions)

We recommends our customers to use special care during bending of the welded axial pins of Primary cells (where applicable).

The pins may be damaged at the welding point if the distance to the bending point is too small. A minimum distance of 5 mm is recommended to avoid damages.

In addition, we recommend the use of a supportive bending tool to sustain the bending point. If these recommendations are followed there is no limit for the angle of bending.

